

- * 2 : w/ Entry & Start System
- * 3 : w/o Entry & Start System
- * 9 : w/ ID Code Box
- *10 : w/o ID Code Box

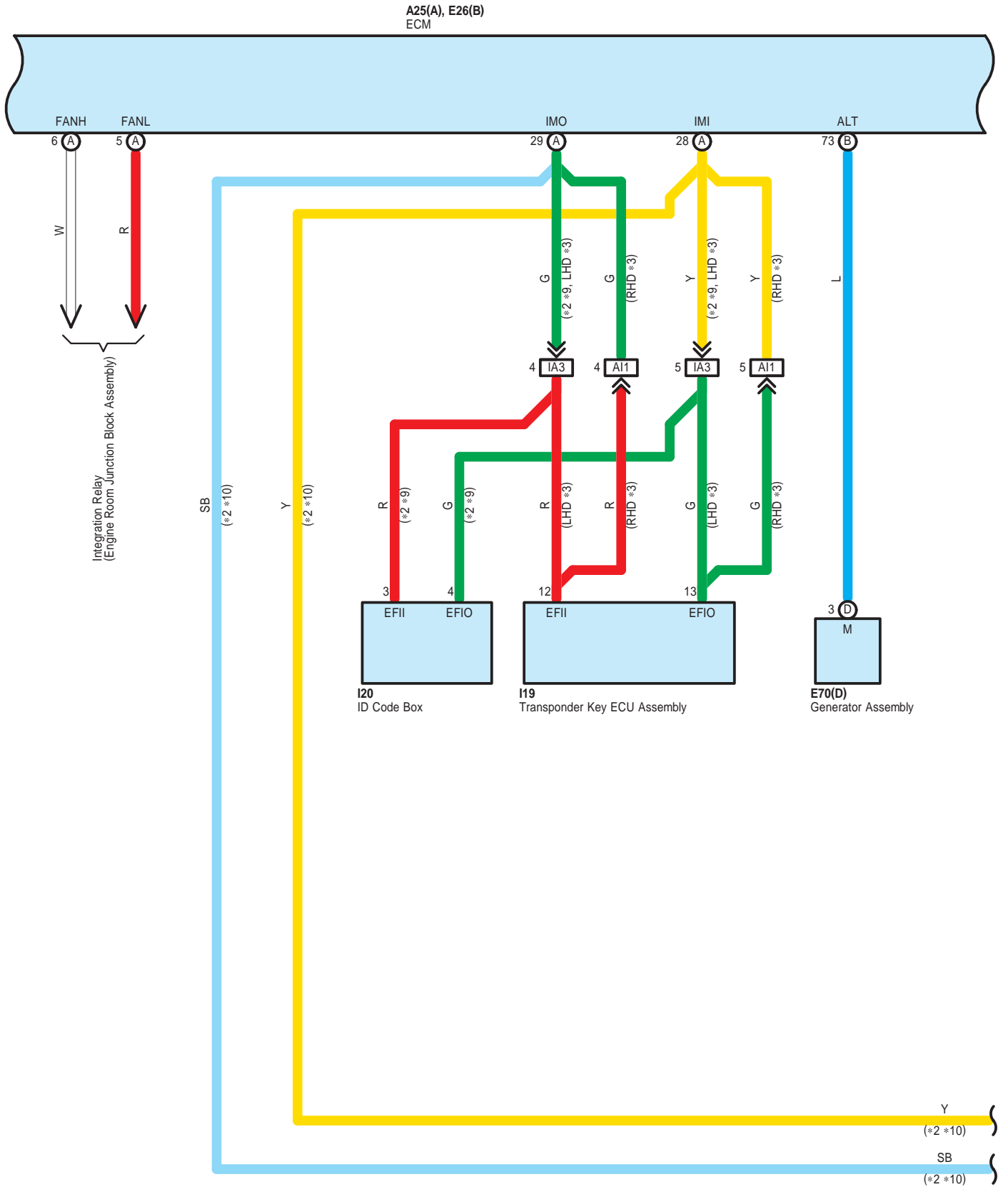

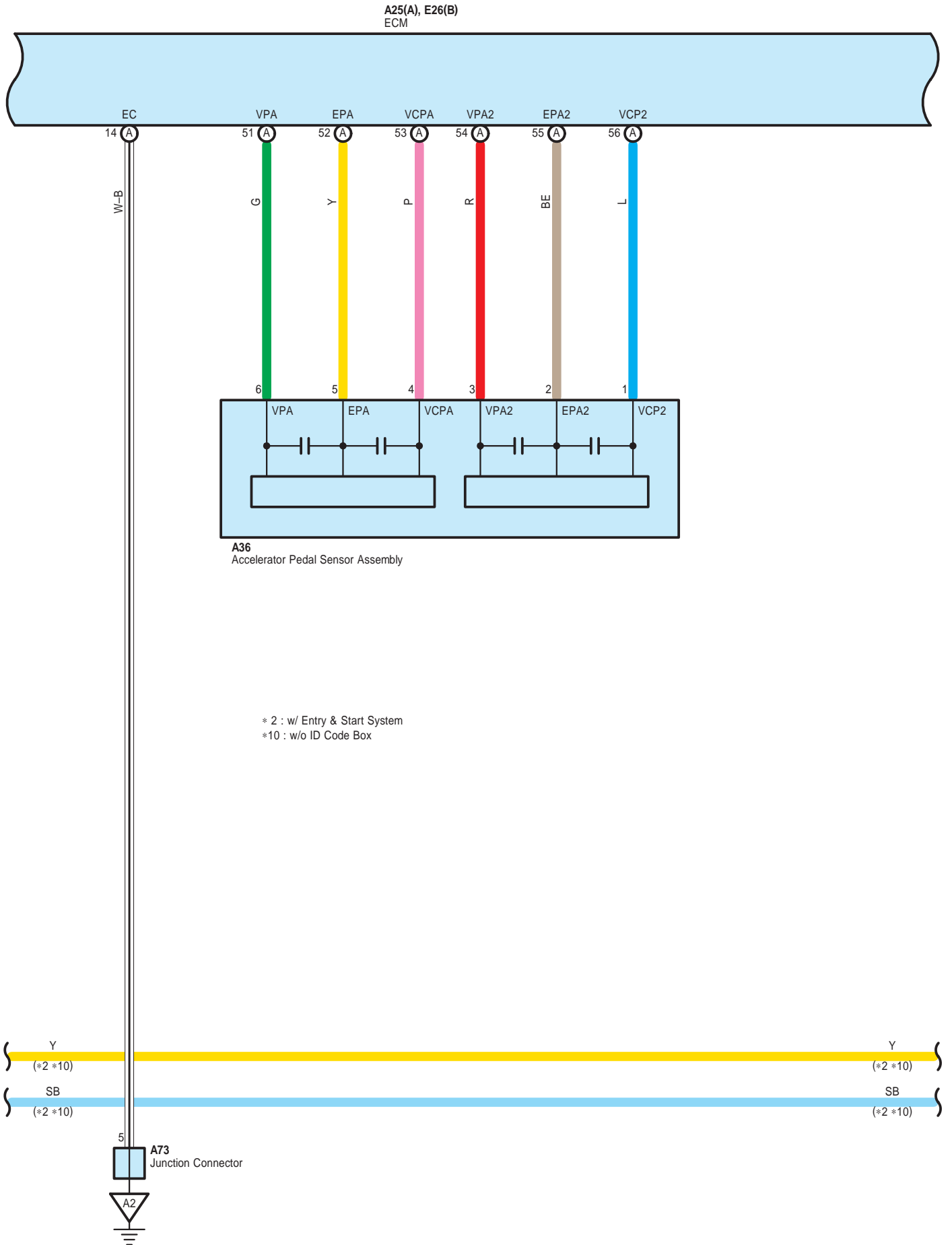

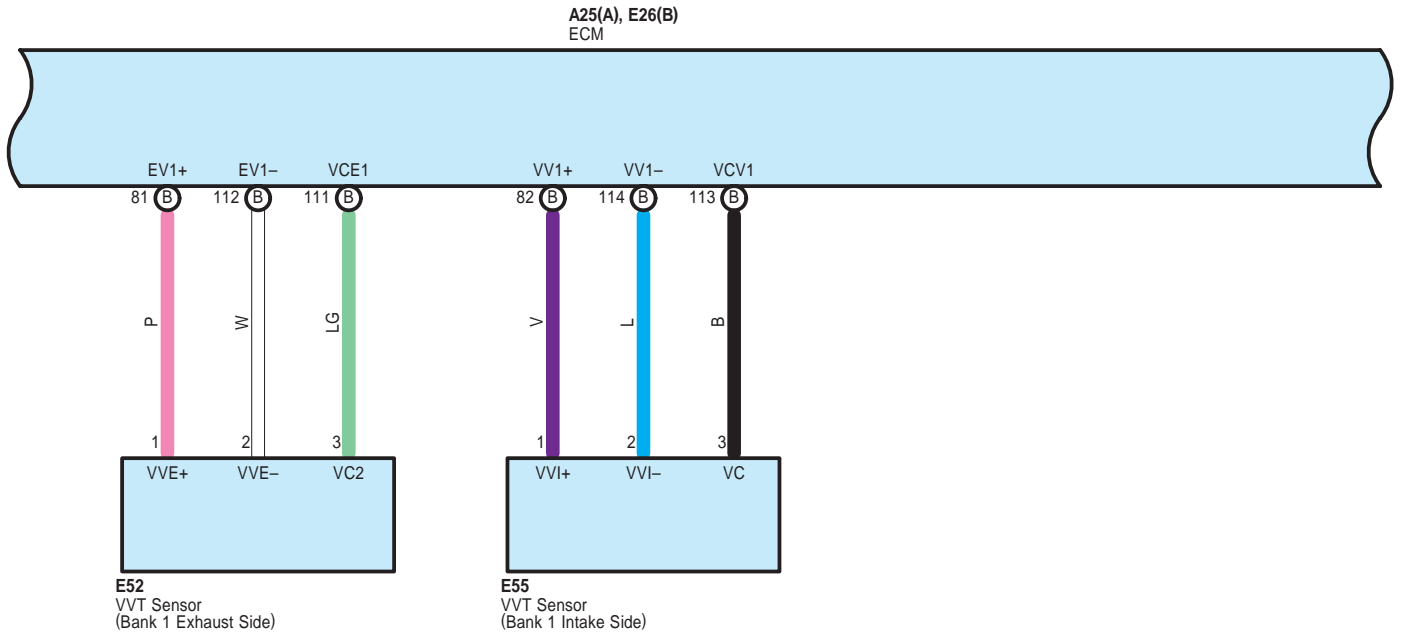

A25(A), E26(B)
ECM

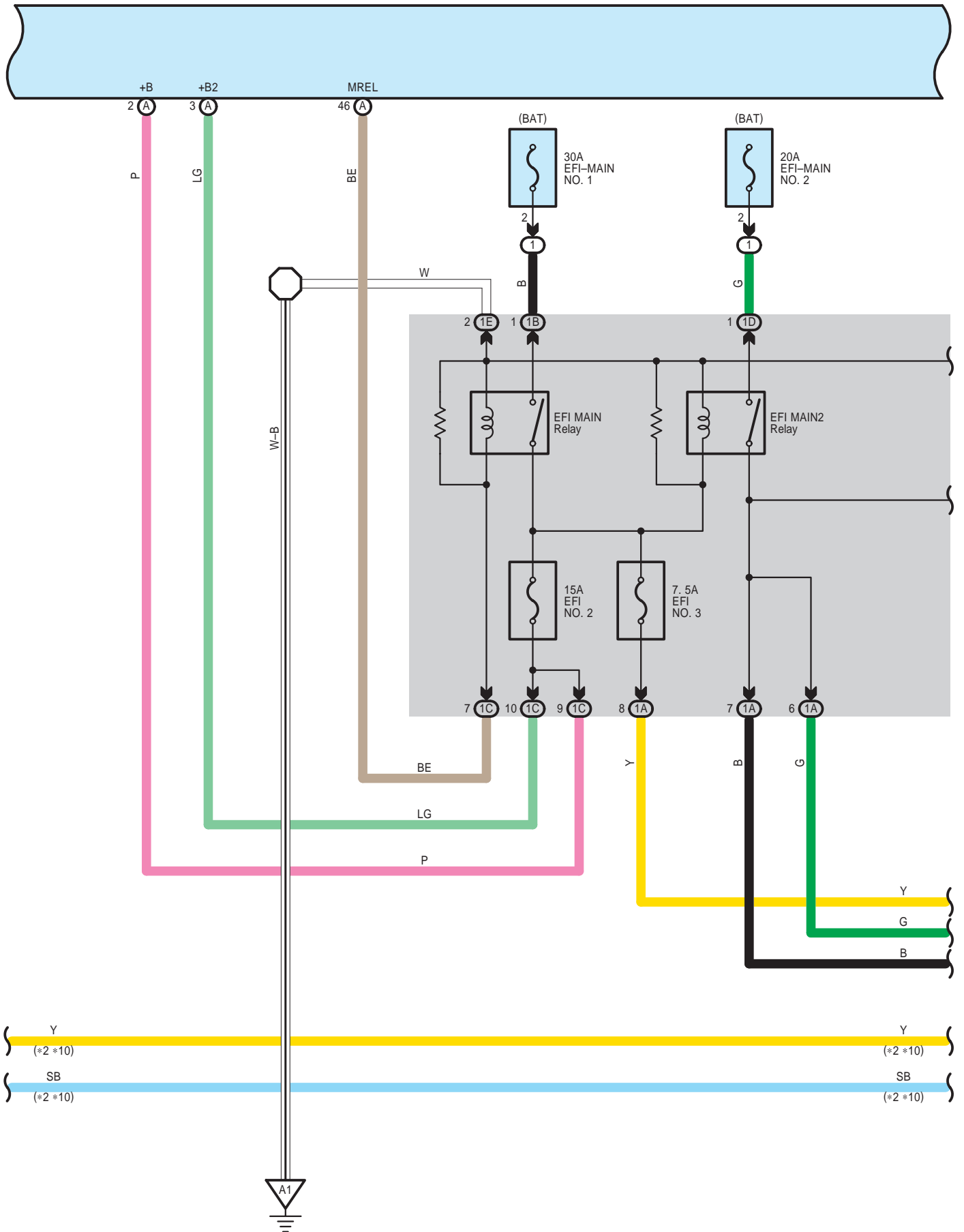

A25(A), E26(B)
ECM

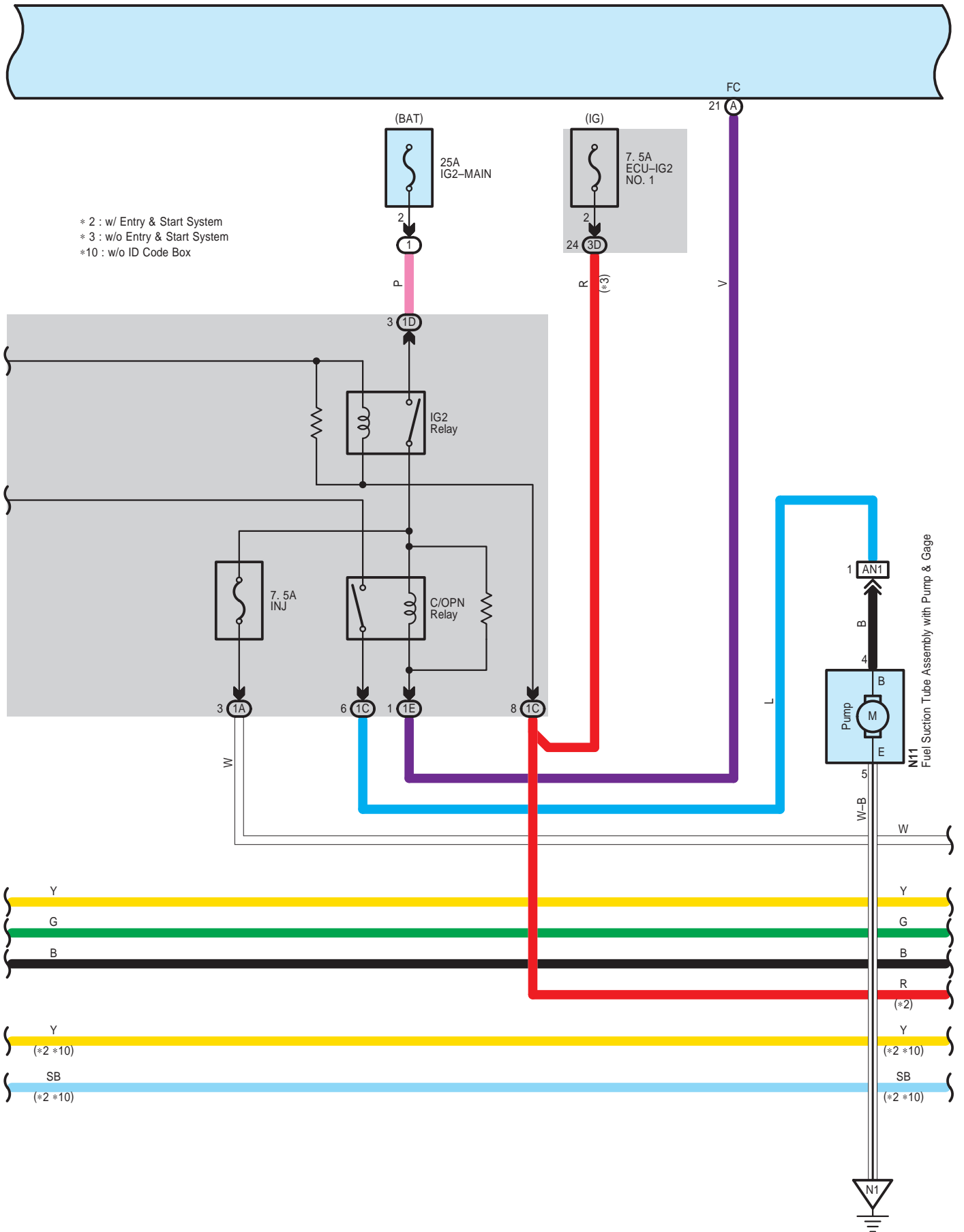

A25(A), E26(B)
ECM

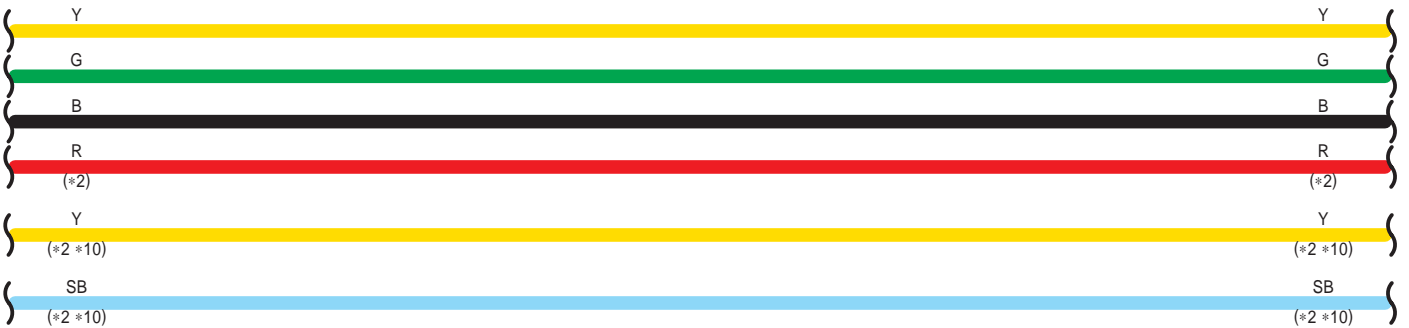
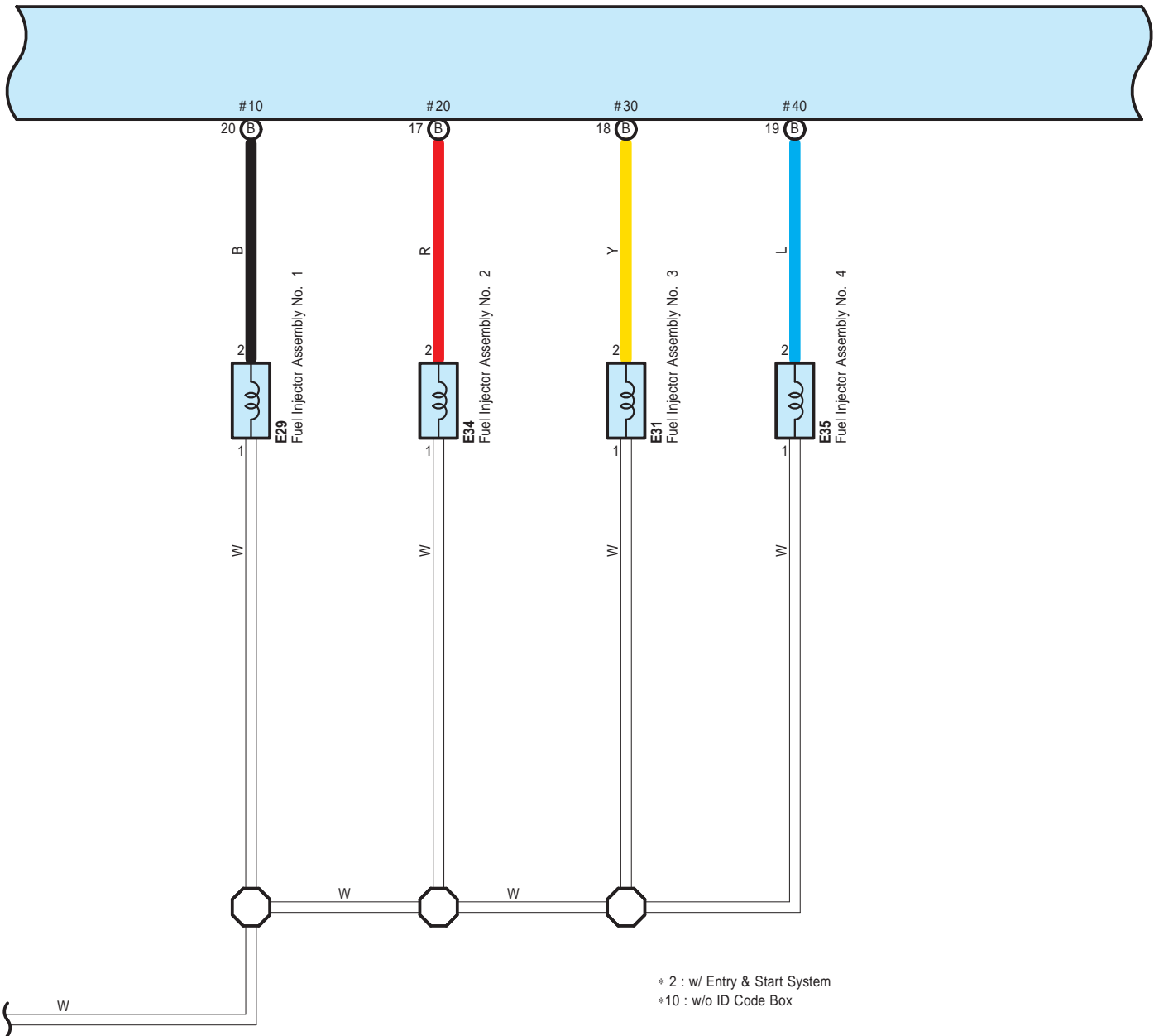

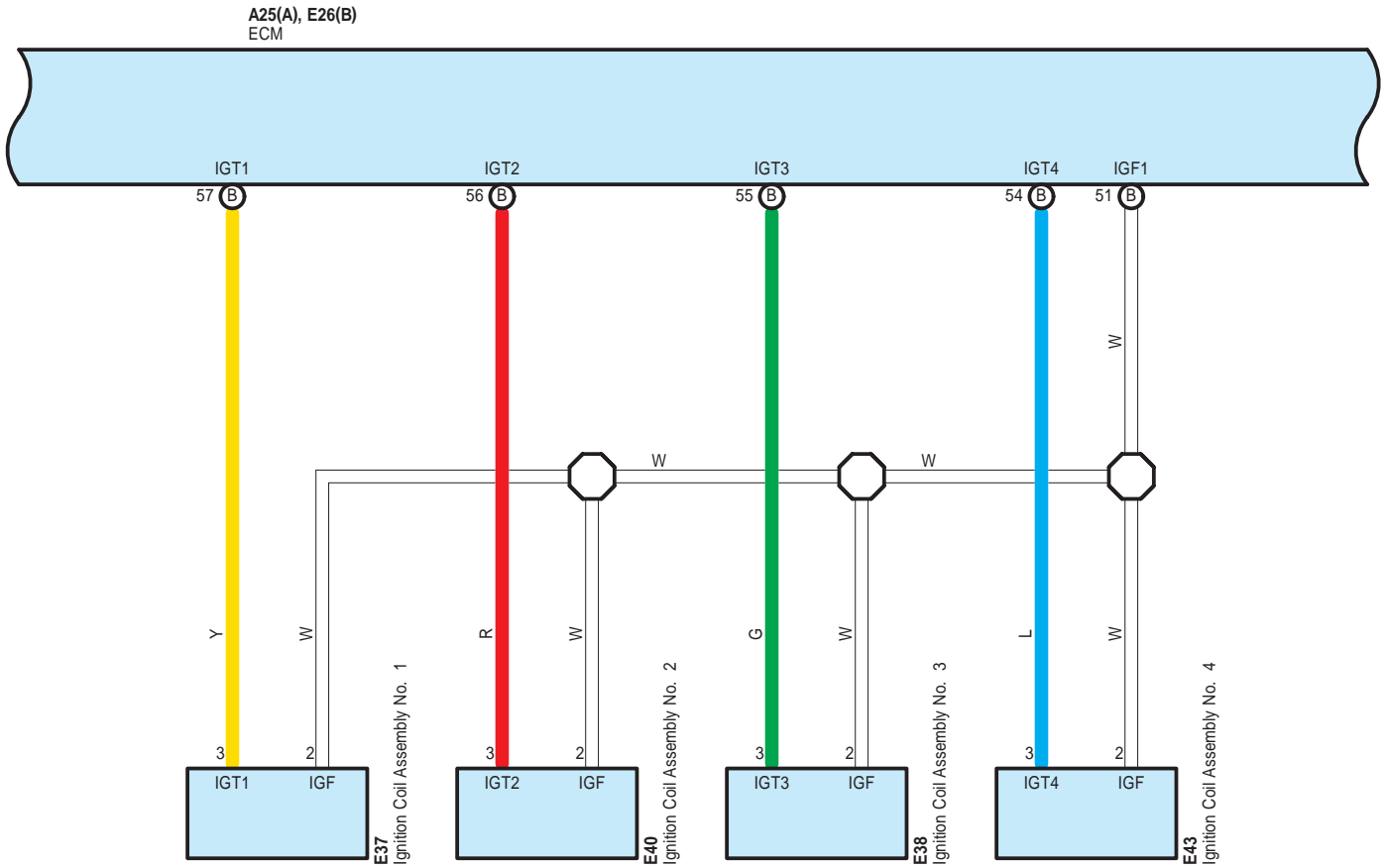

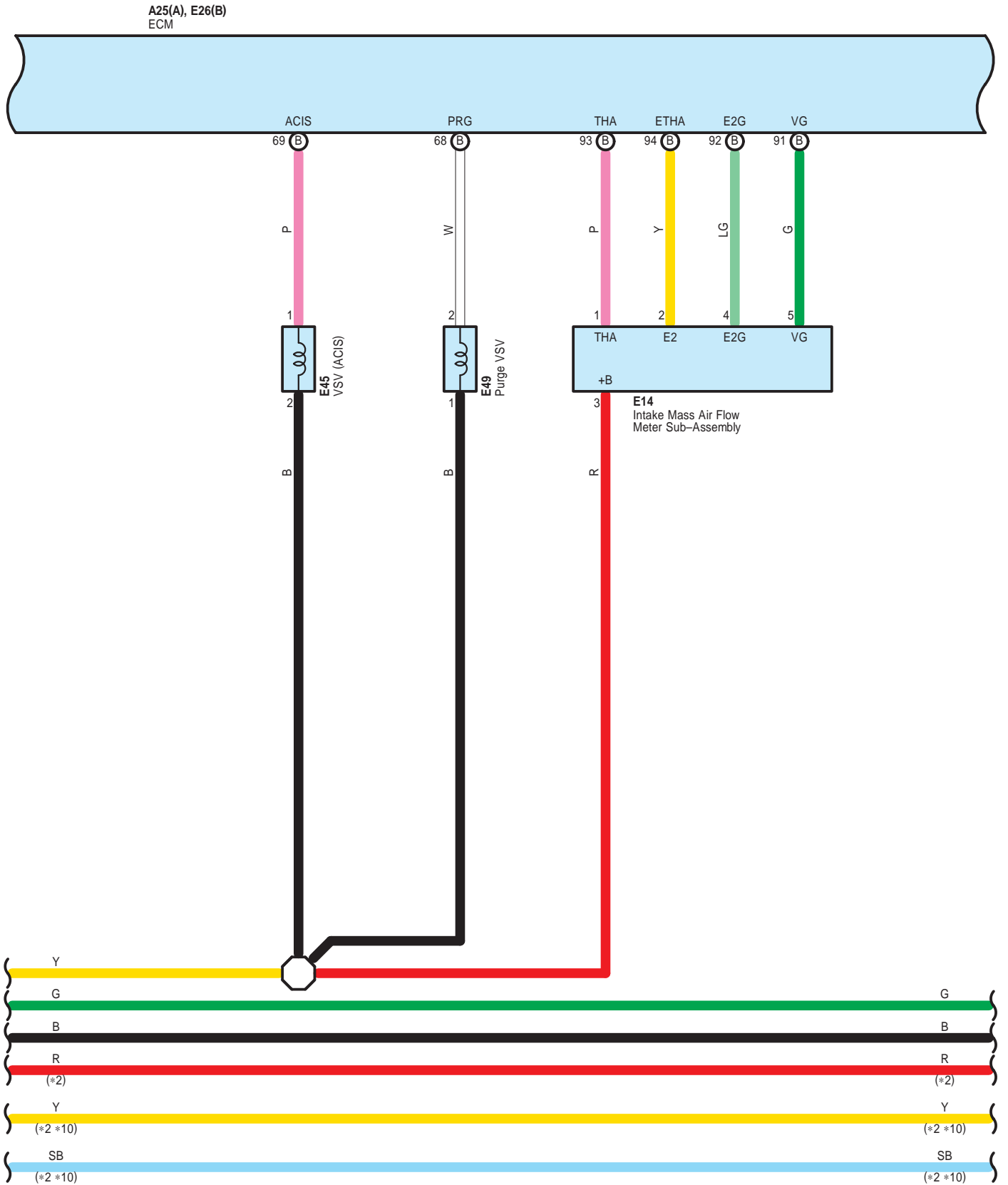

A25(A), E26(B)
ECM

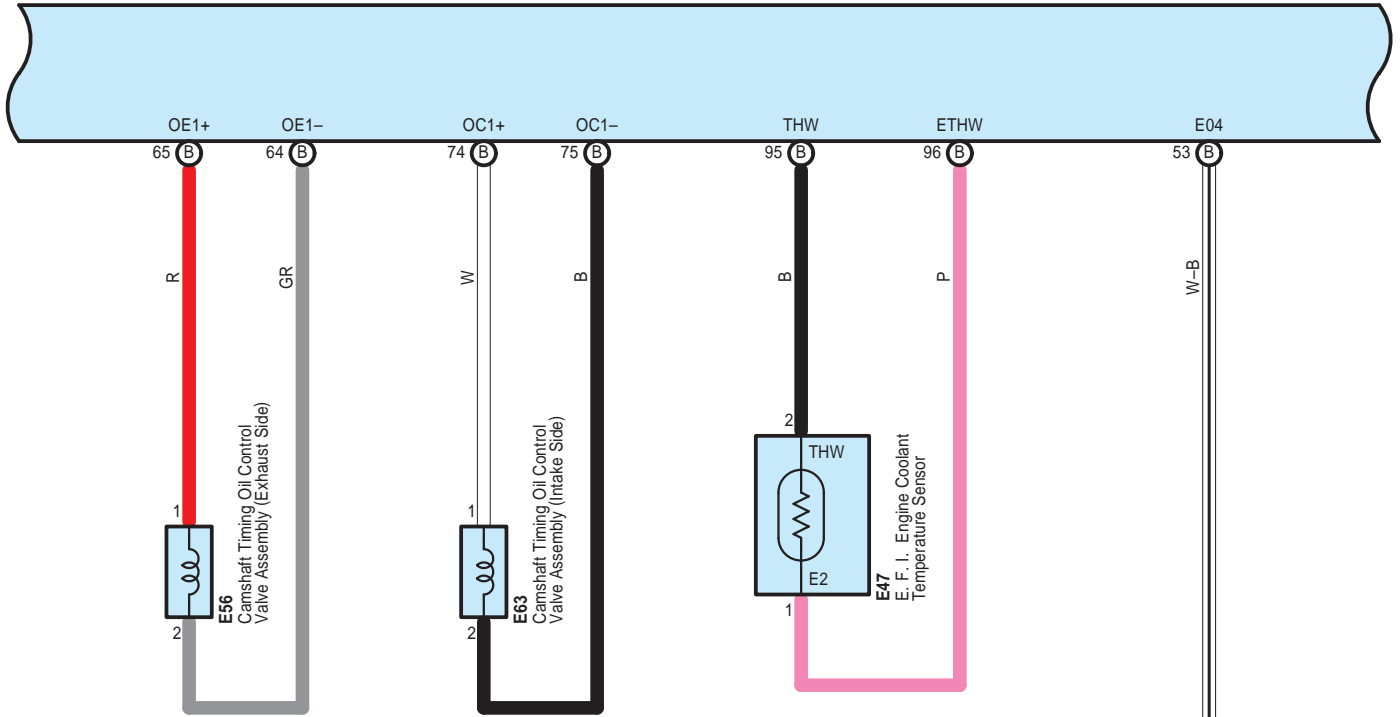

* 2 : w/ Entry & Start System
*10 : w/o ID Code Box

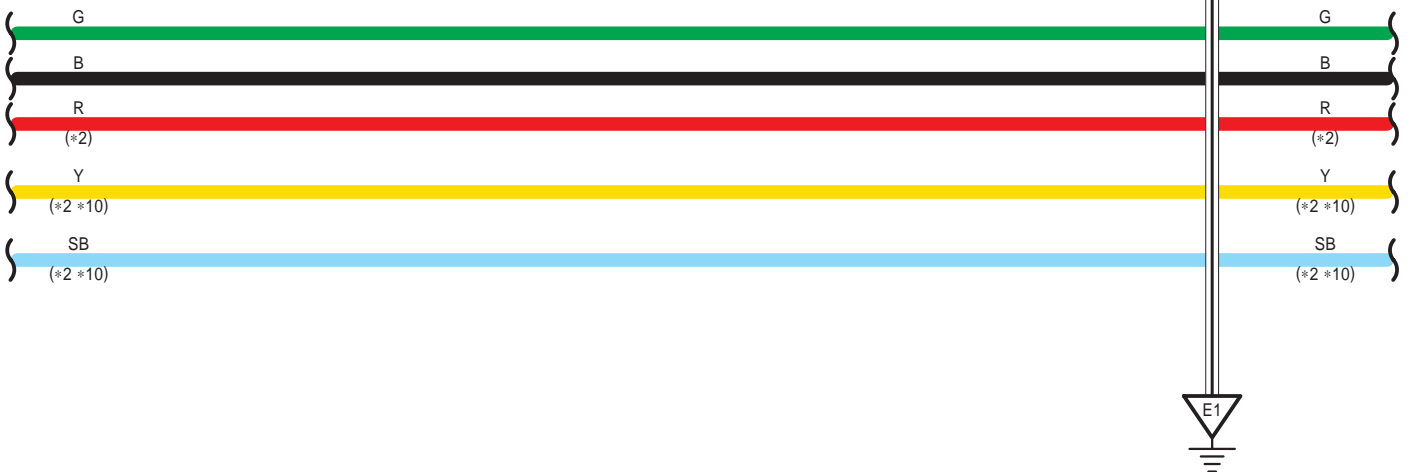

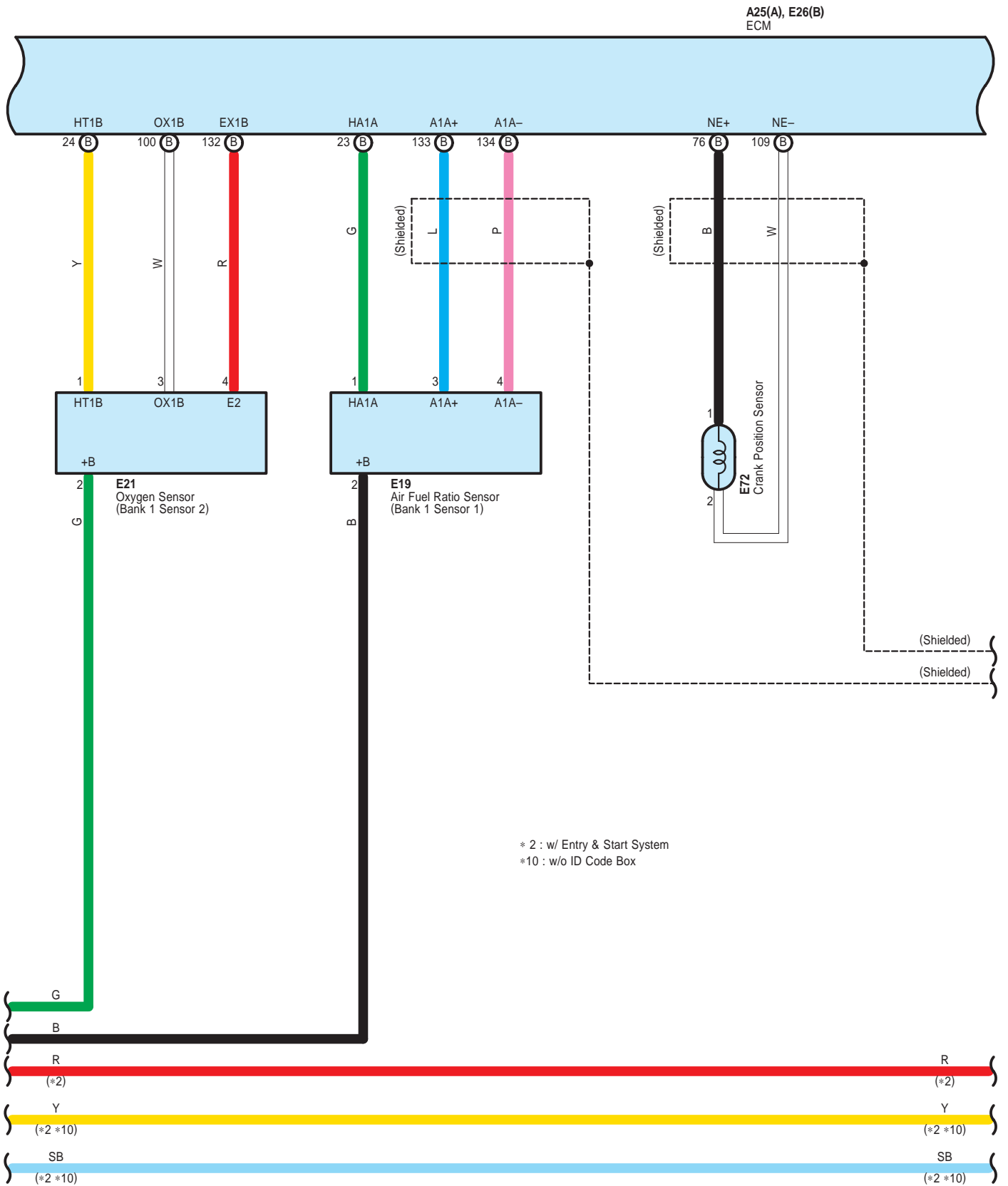

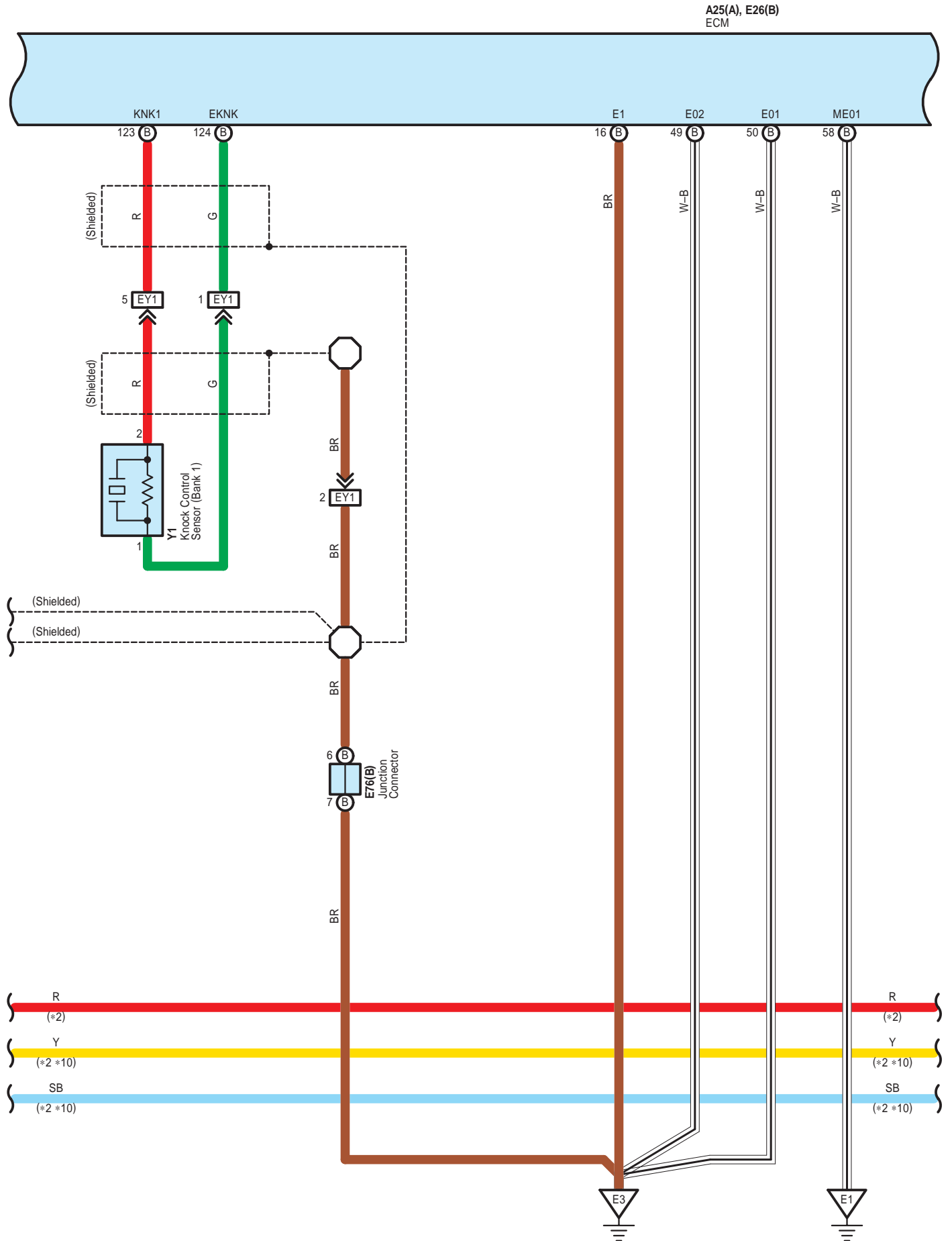

A25(A), E26(B)
ECM

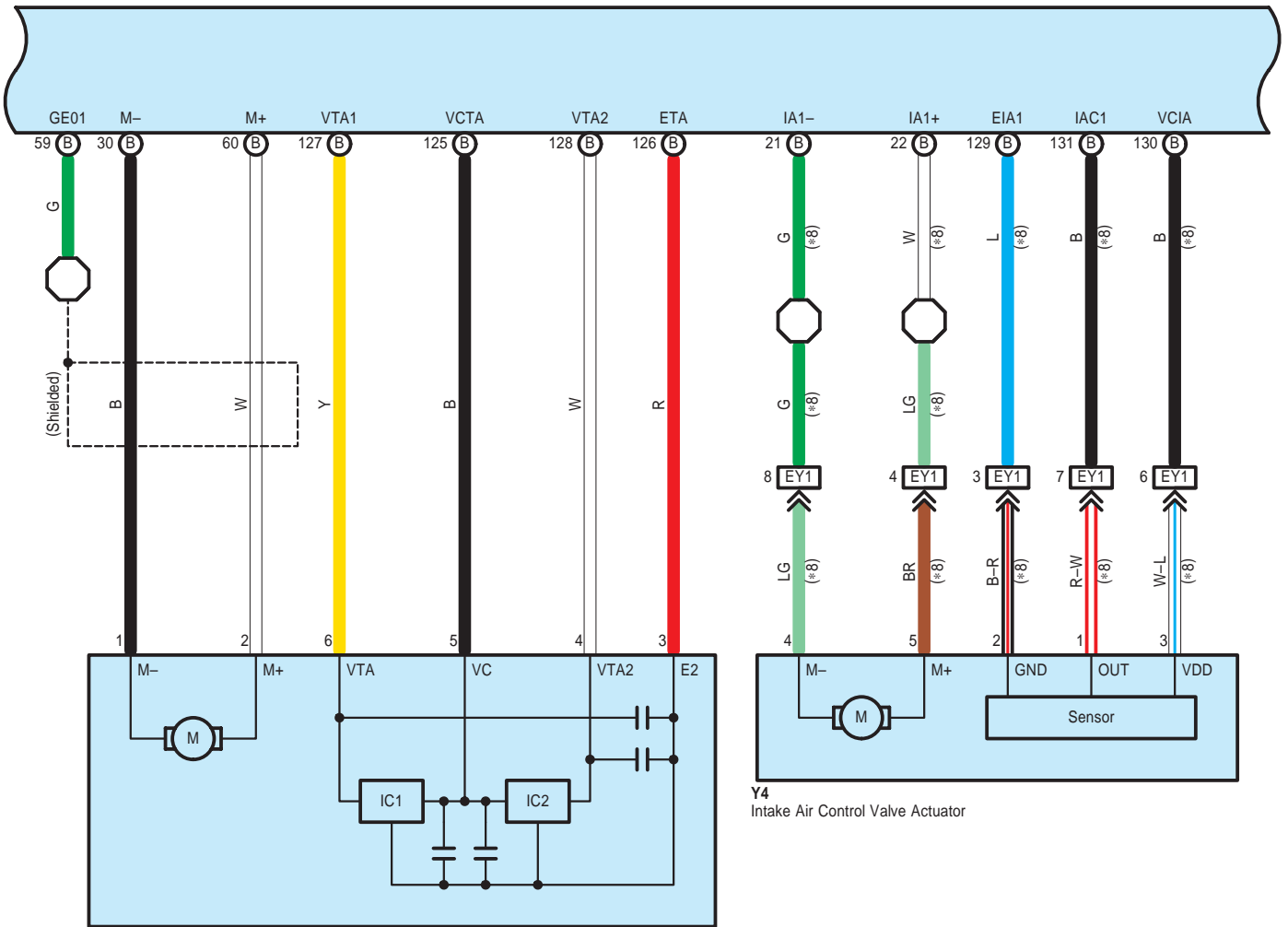

E16
Throttle Body Assembly with Motor

Y4
Intake Air Control Valve Actuator

- * 2 : w/ Entry & Start System
- * 8 : w/ Tumble Control Valve
- *10 : w/o ID Code Box



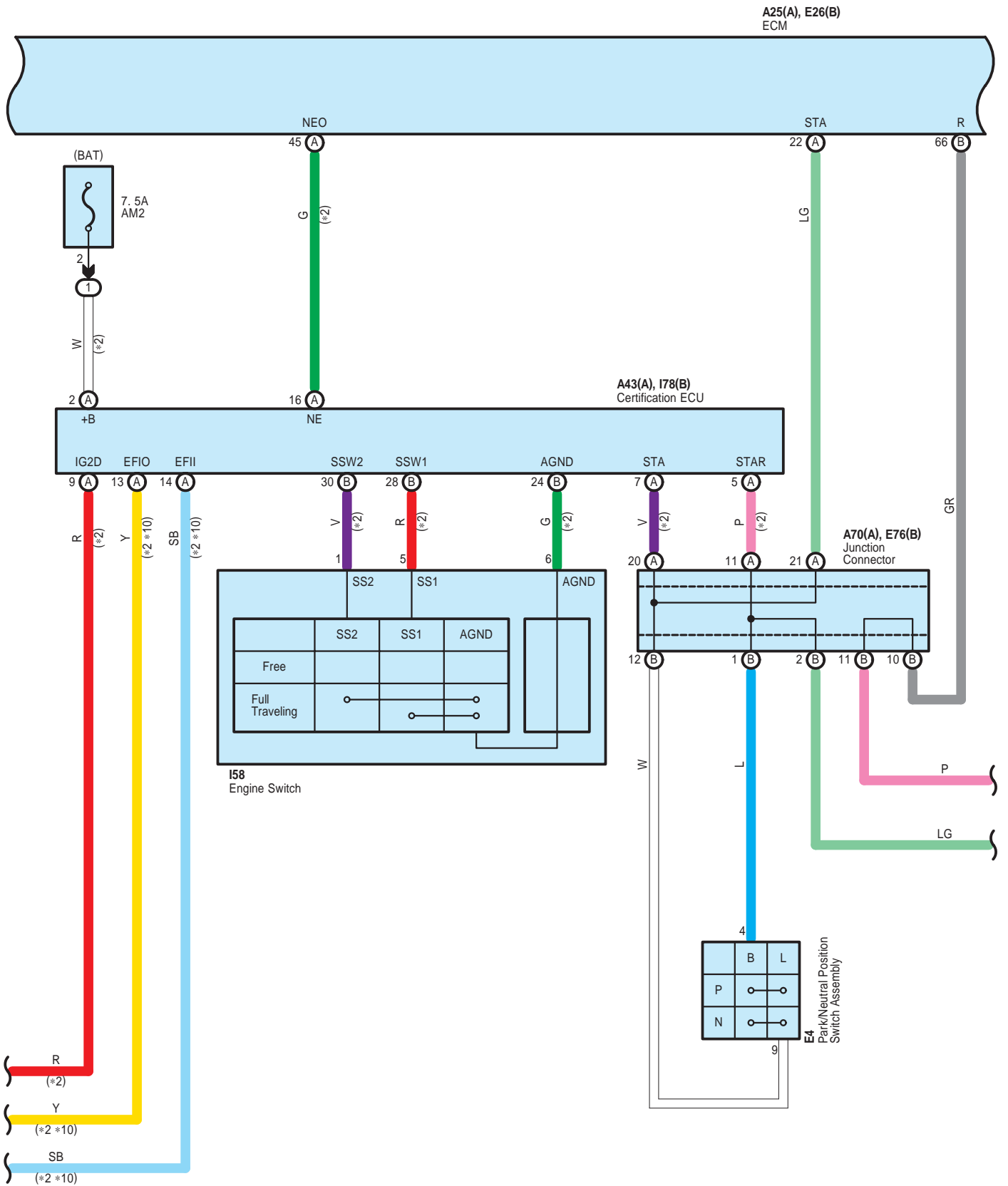

A25(A), E26(B)
ECM

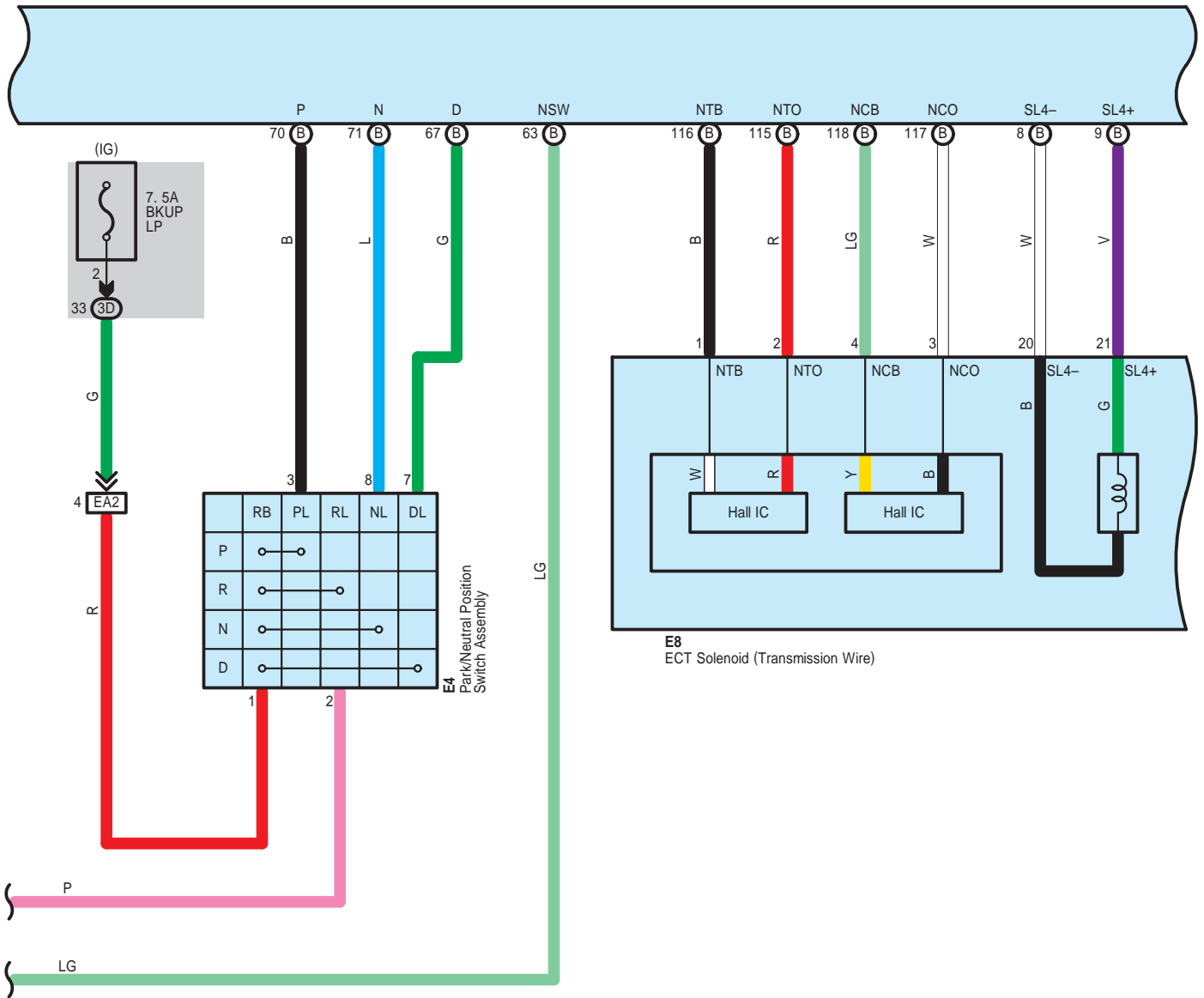

A25(A), E26(B)
ECM

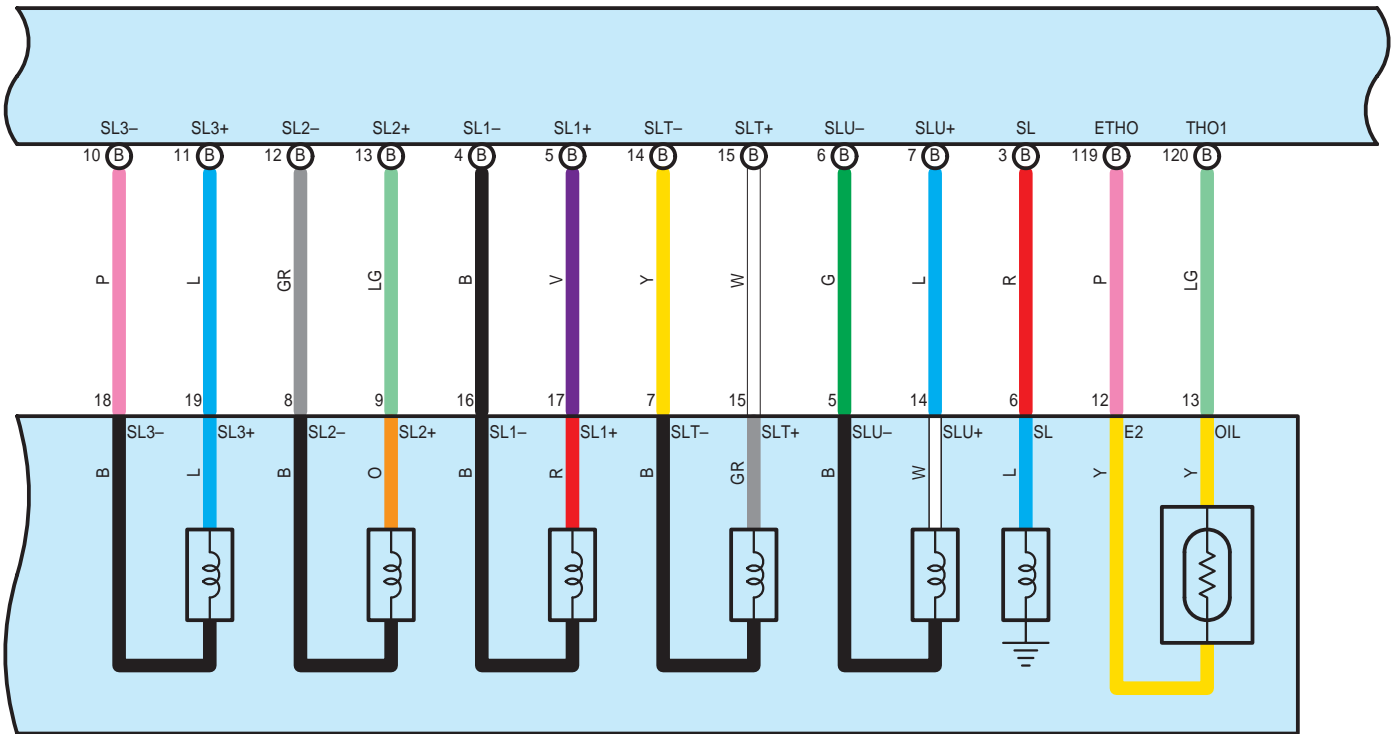

E8
ECT Solenoid (Transmission Wire)

A25(A), E26(B)
ECM

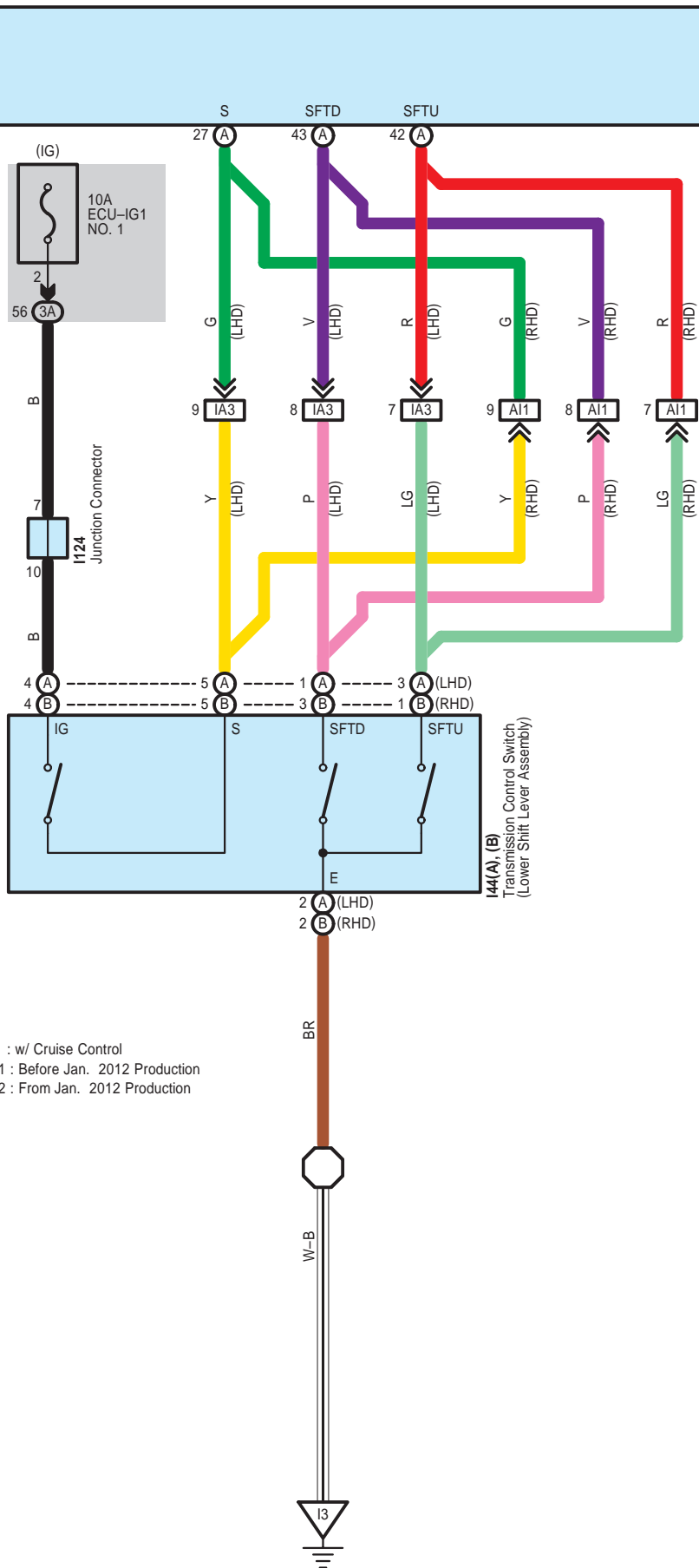

- * 1 : w/ Cruise Control
- * 11 : Before Jan. 2012 Production
- * 12 : From Jan. 2012 Production

A25(A), E26(B)
ECM

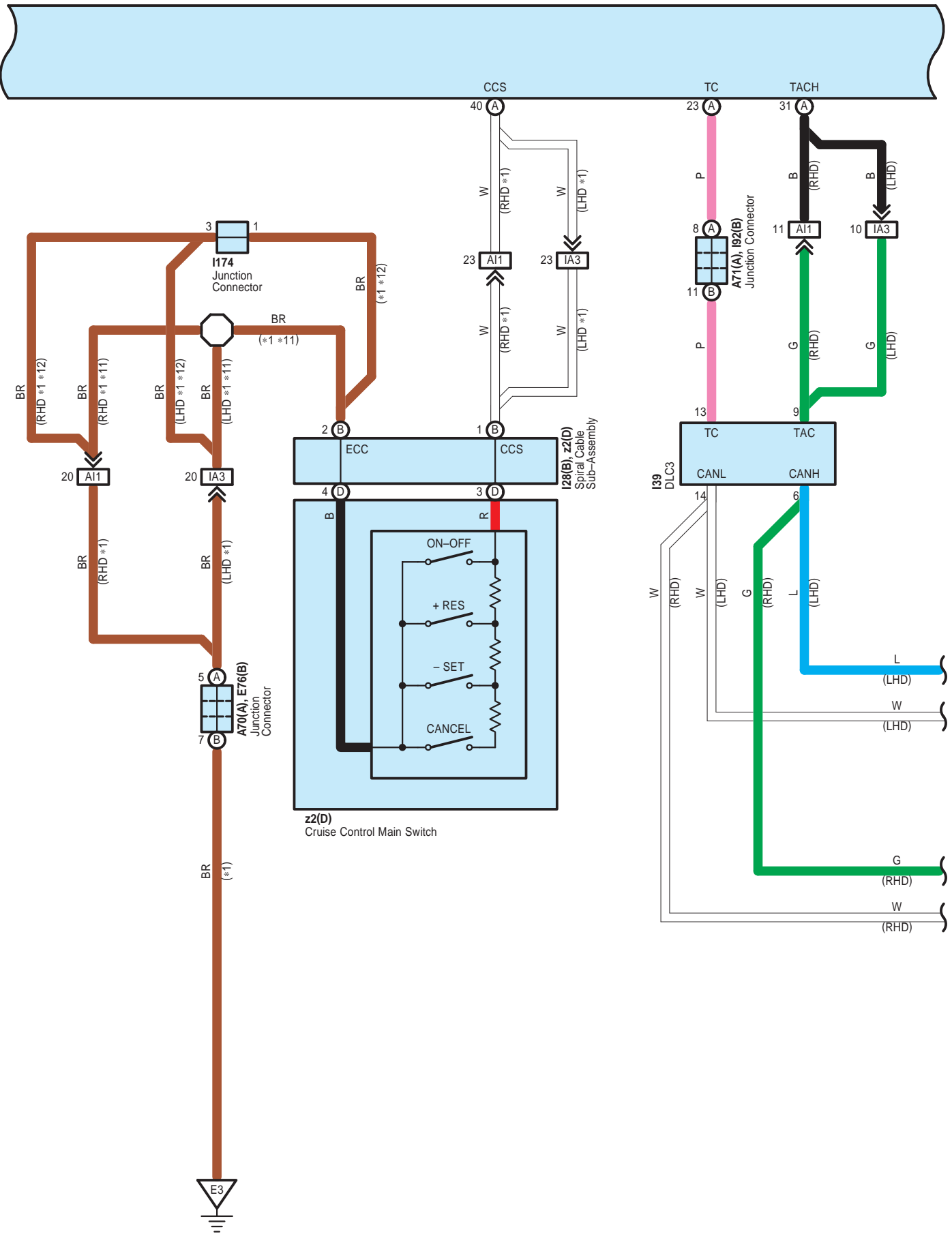

A25(A), E26(B)
ECM

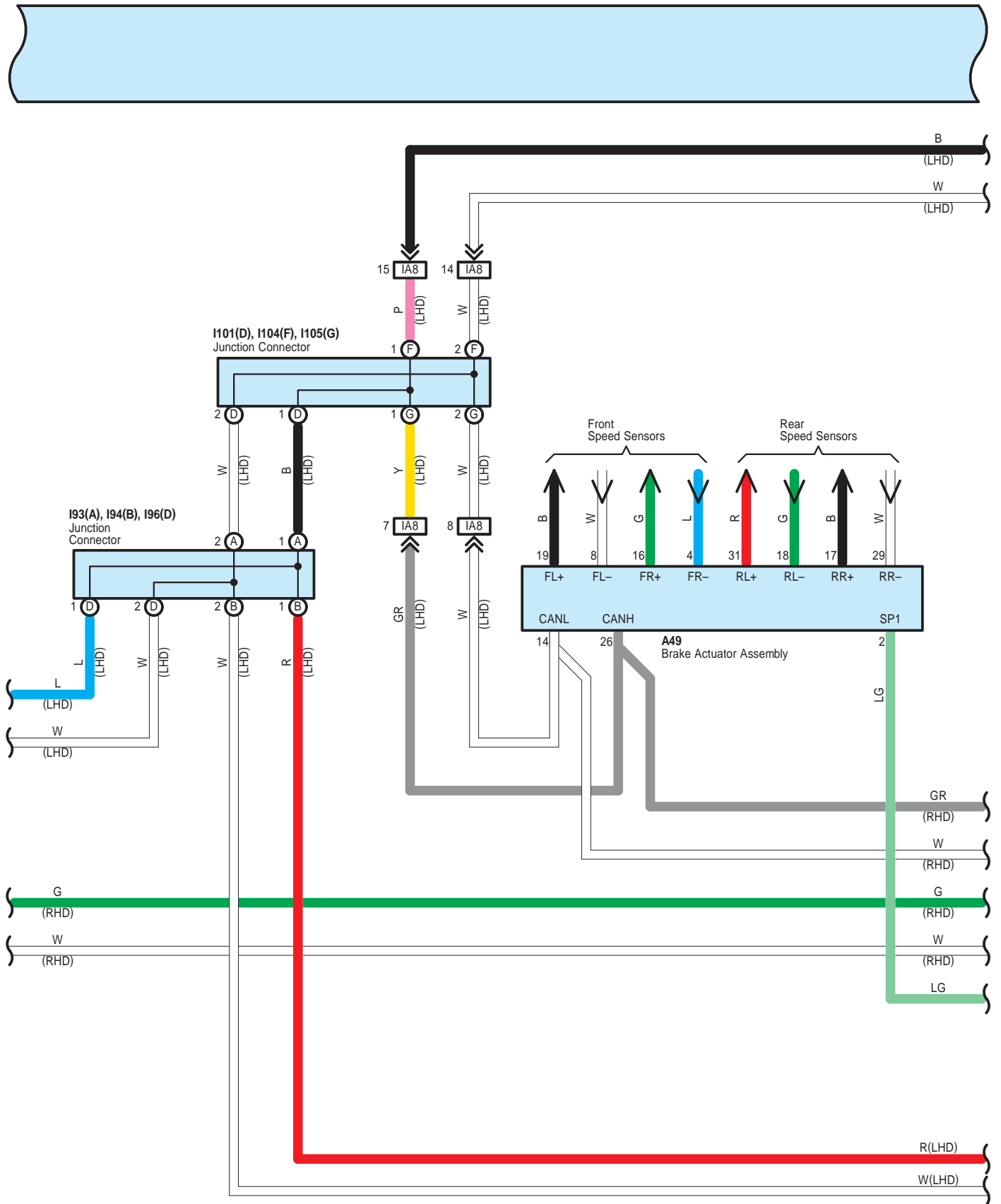

* 6 : LHD w/ Headlight Beam Level Control (Automatic)
 * 7 : LHD w/ Adaptive Front-Lighting System,
 LHD w/ Headlight Beam Level Control (Manual)

A25(A), E26(B)
 ECM

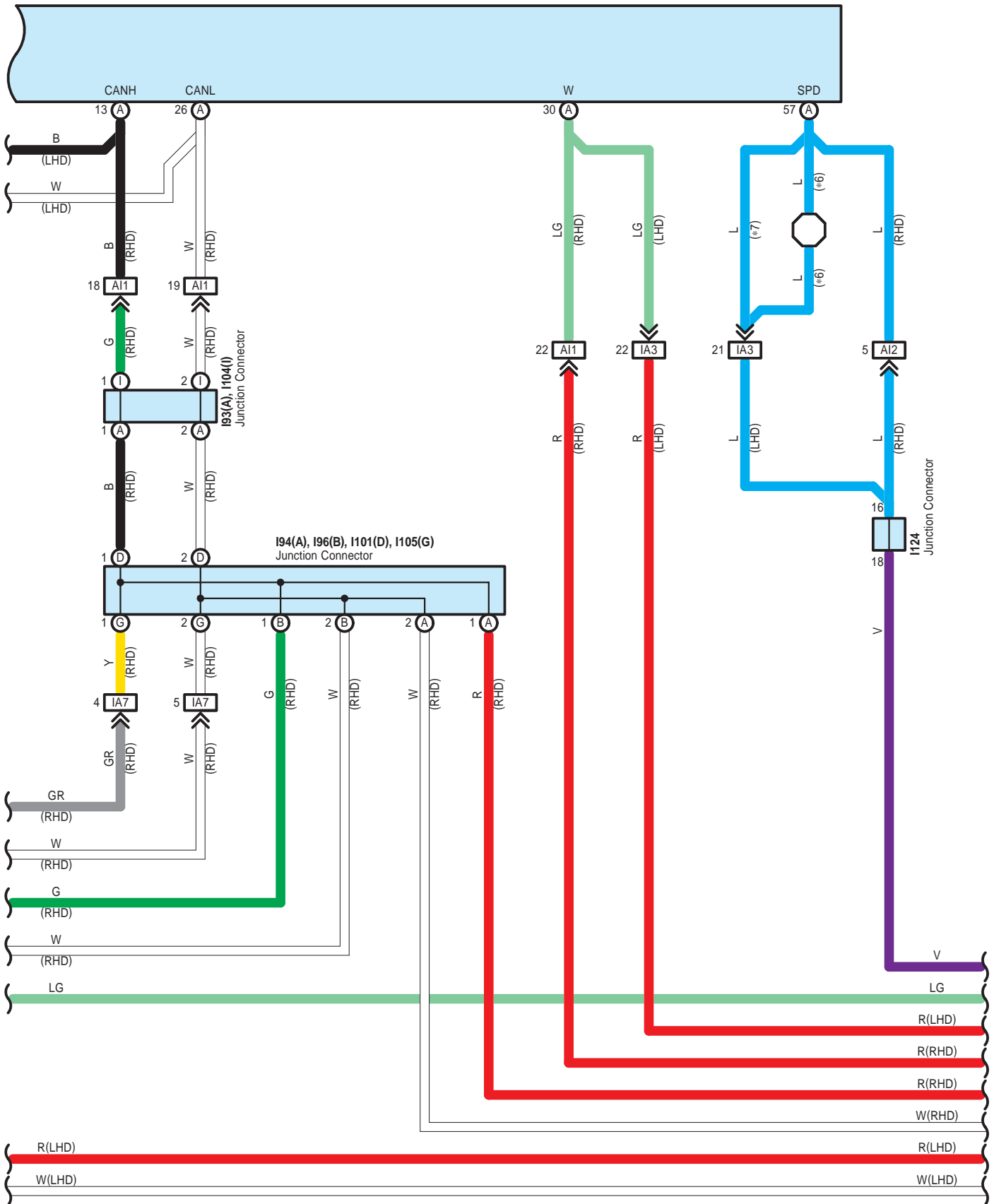

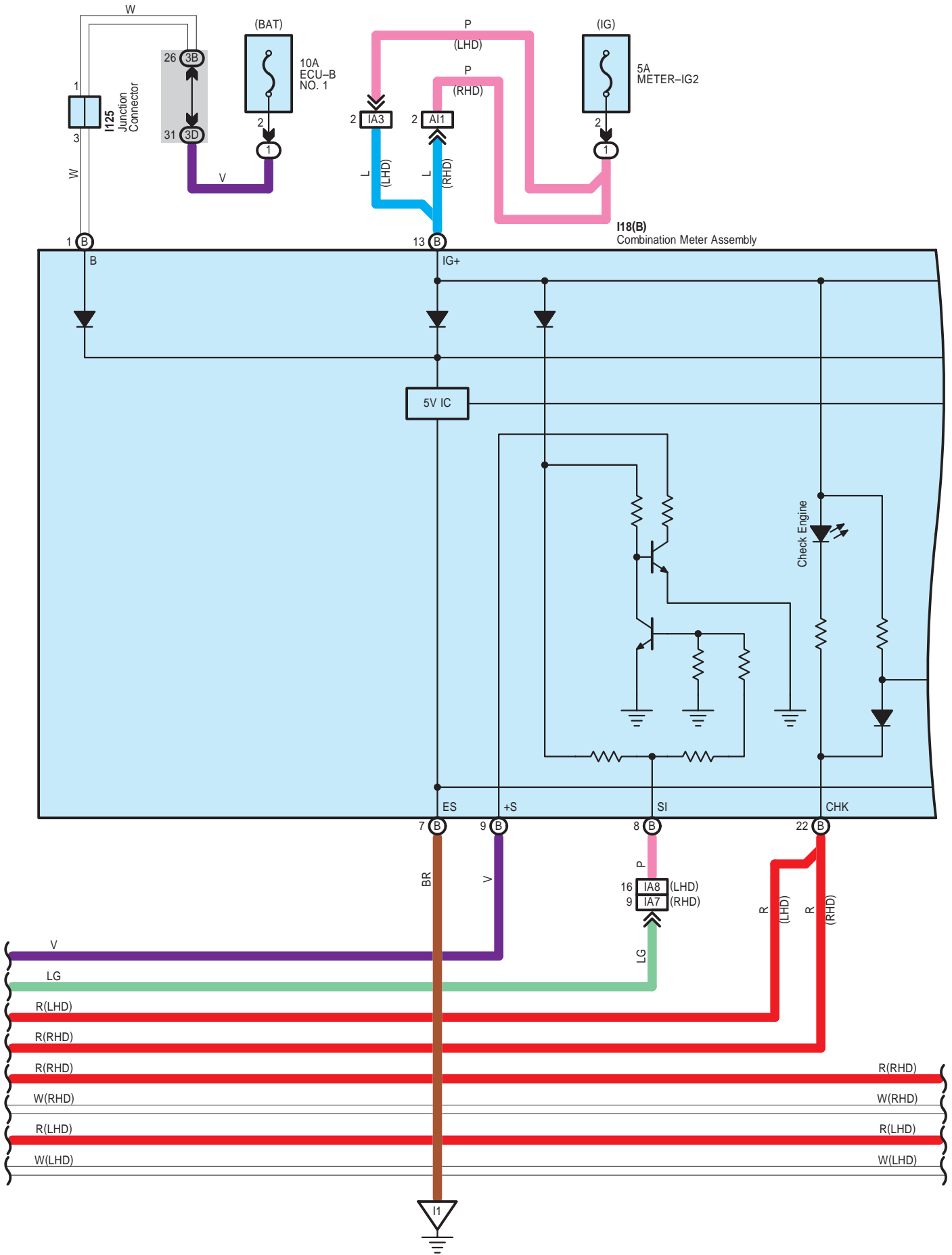

118(B)
Combination Meter Assembly

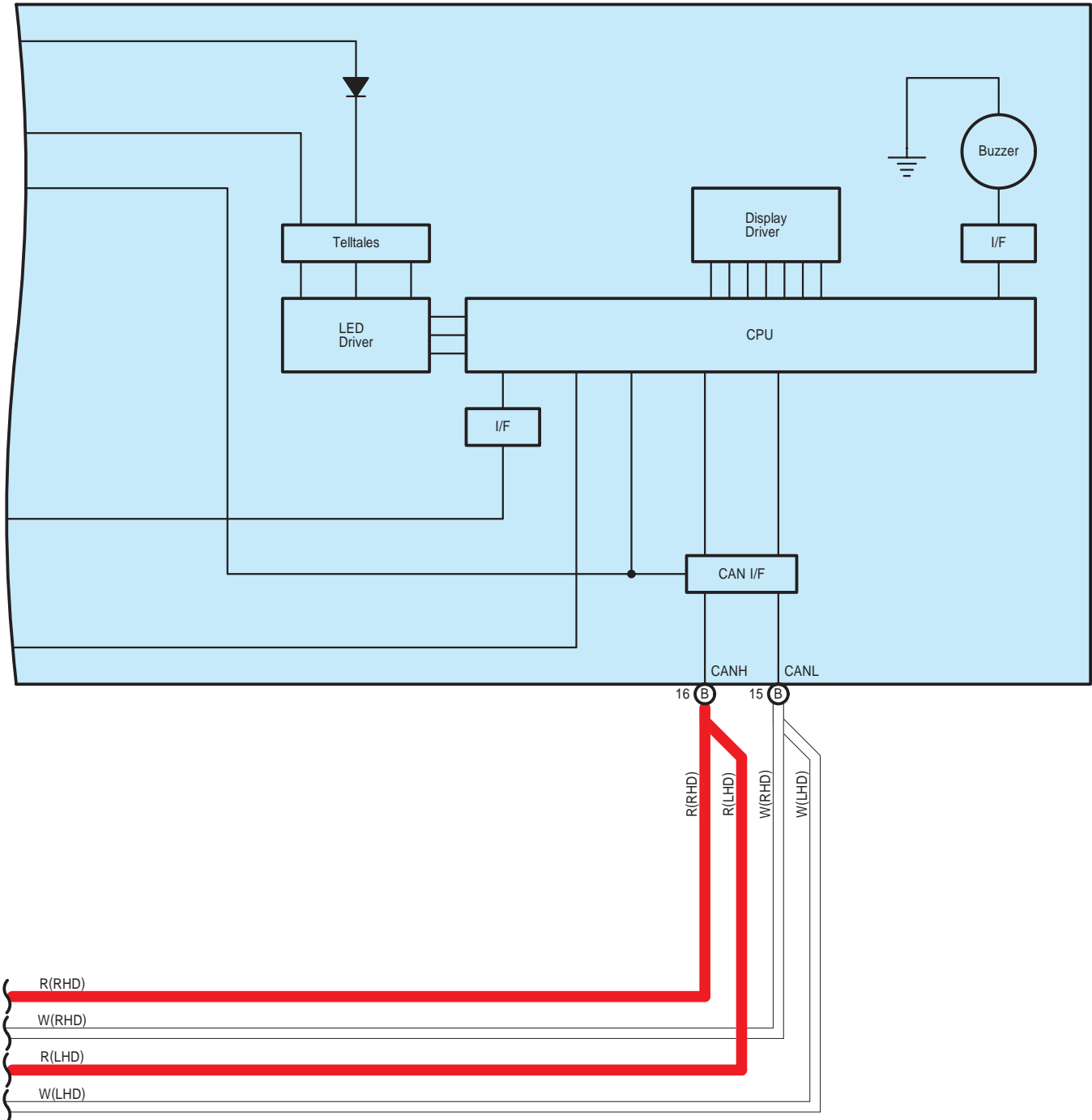

A 25
Black

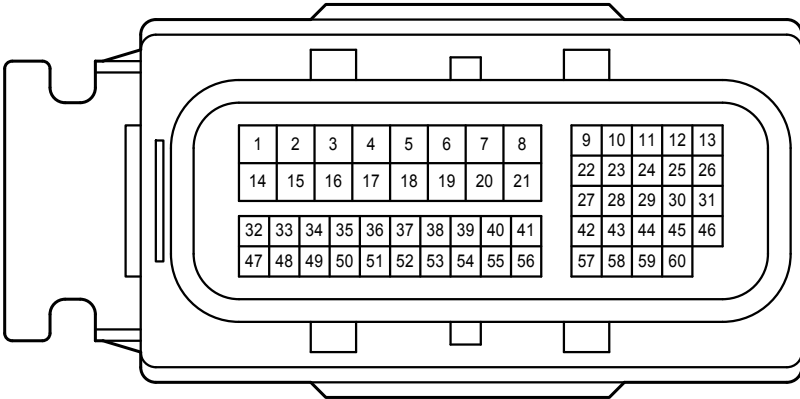

A 33
White

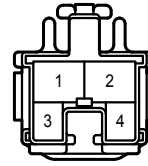

A 36
Black

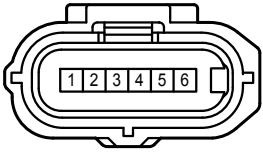

A 43
White

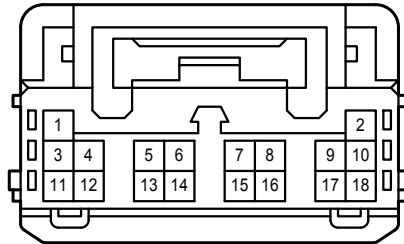

A 49
Black

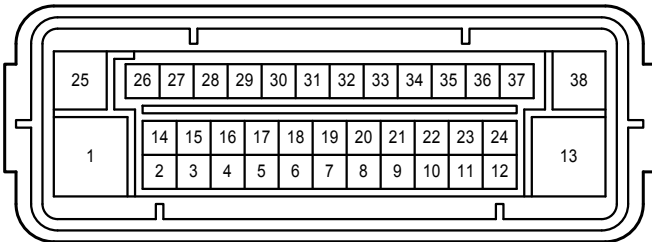

A 70
White

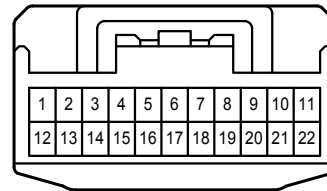

A 71
Gray

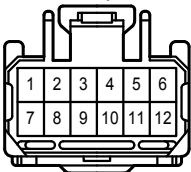

A 73
Gray



E 4
Gray

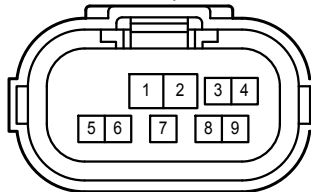

E 8
Black

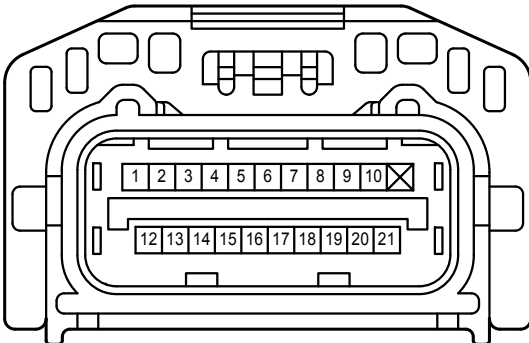

E 14
Black



E 16
Black

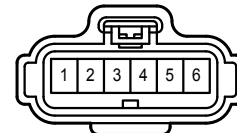

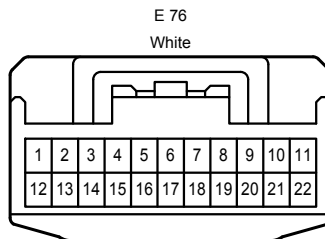
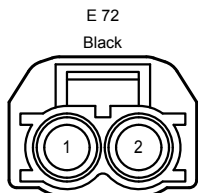
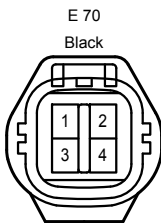
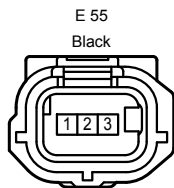
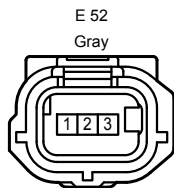
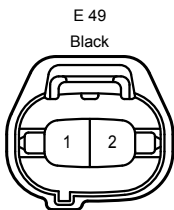
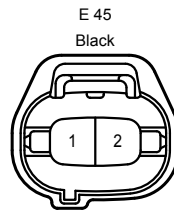
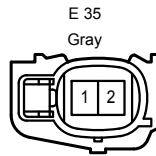
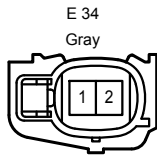
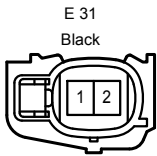
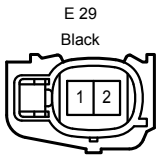
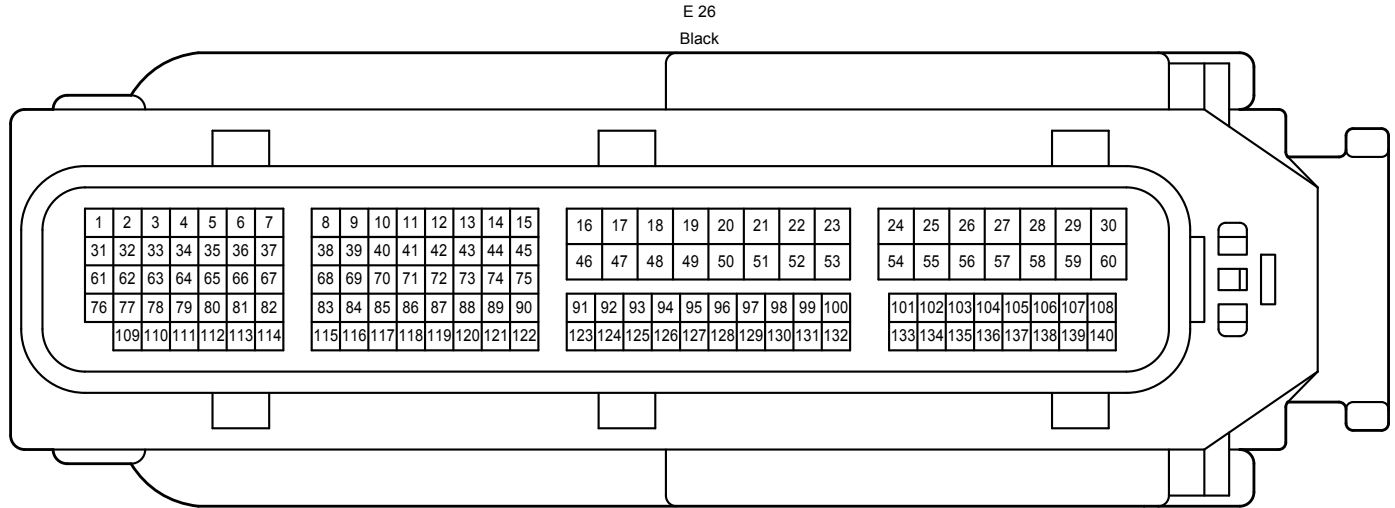

I 18
Black

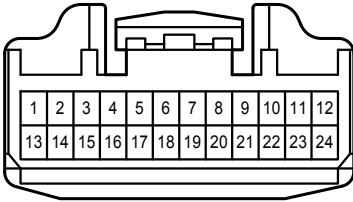

I 19
Black

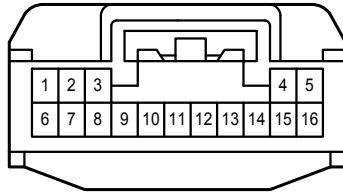

I 20
White

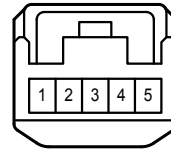

I 28
Black

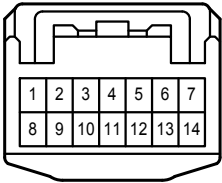

I 39
White

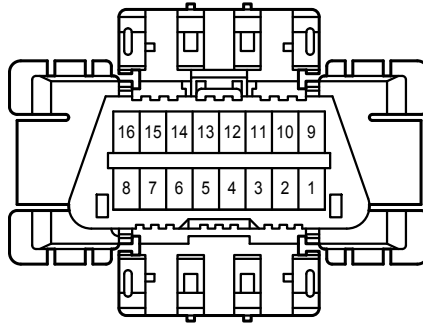

I 44
White

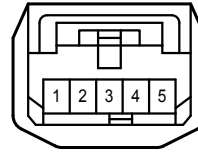

I 58
Black

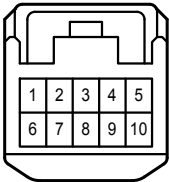

I 78
White

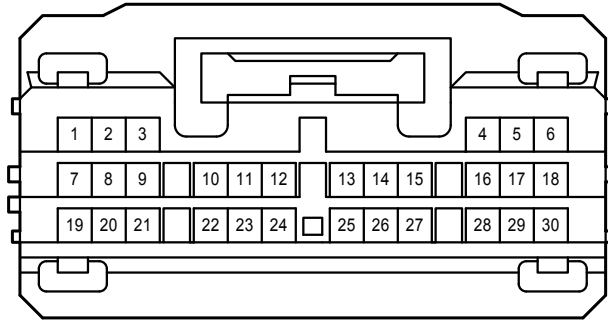

I 92
Gray

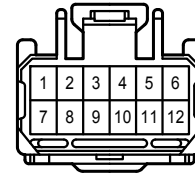

I 93
White

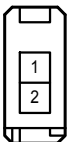

I 94
White

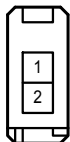

I 96
White

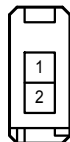

I 101
White

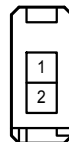

I 104
White

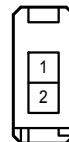

I 105
White

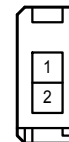

I 124
White

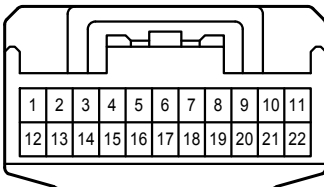

I 125
Gray

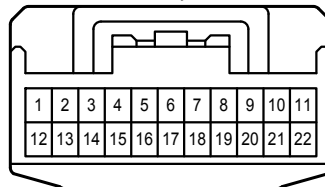

I 174
White

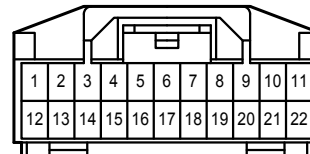

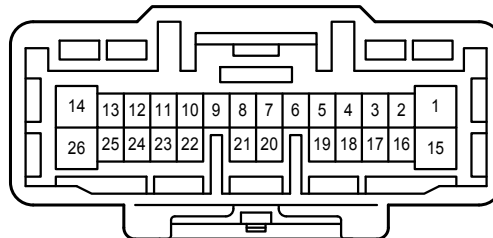
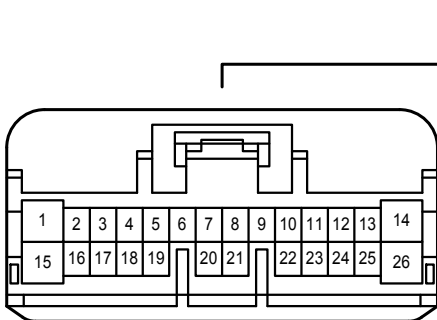
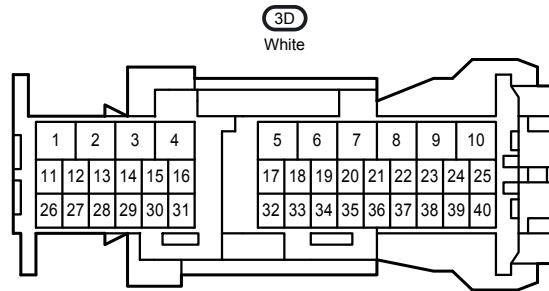
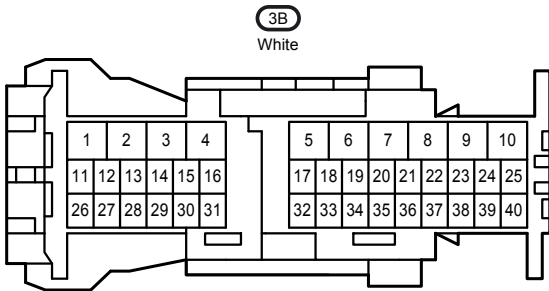
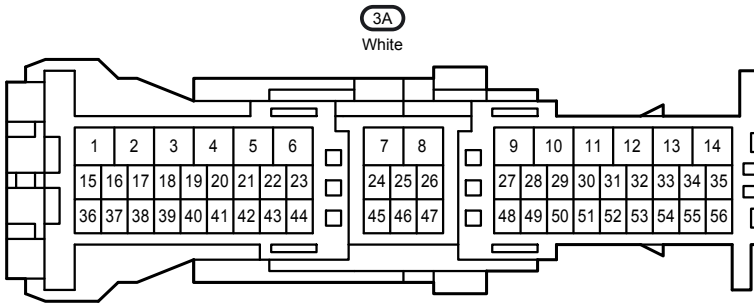
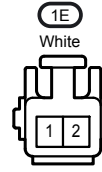
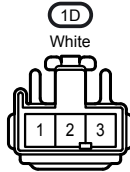
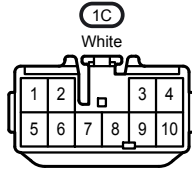
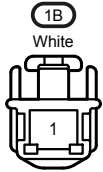
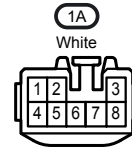
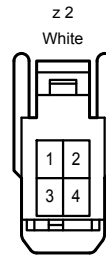
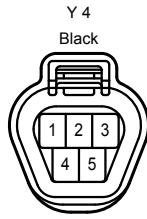
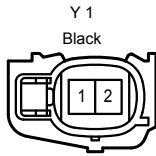
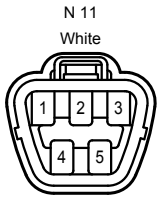

AI2
White

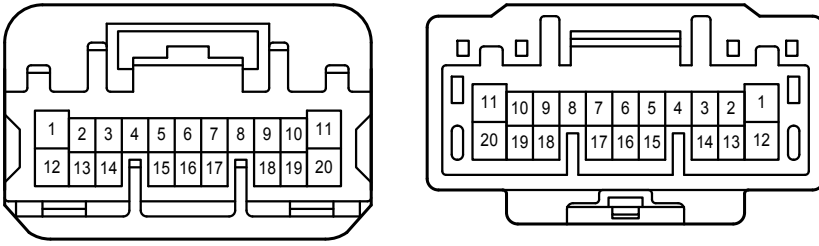

AN1
White

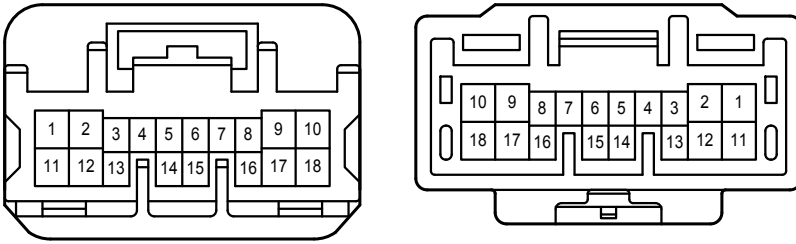

EA2
White

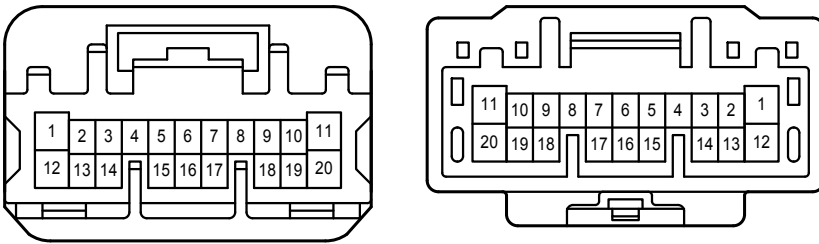

EY1
Gray

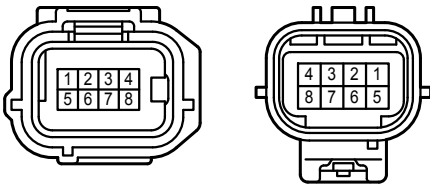

IA3
Blue

